

## YFBCSL/R- FJ

### INSTALLATION, OPERATION AND MAINTENANCE MANUAL



Read and retain these instructions for future reference. Review all information carefully before assembling, installing, operating, or servicing the product described.

To reduce the risk of injury or property damage, all safety instructions and precautions must be strictly followed. Failure to comply with these instructions, as well as applicable codes and regulations, may result in serious injury, death, or property damage.

Improper installation, operation, or maintenance may also void applicable warranties. It is the responsibility of the user to ensure that all procedures are performed by qualified personnel and in accordance with these instructions.

## Included sections

Naming Convention	3
General Safety Information	4
Receiving, Unpacking, Handling and Storage	5
Inspection and Maintenance During Storage	6
Removing from Storage	7
Lifting	7
Controlling Vibration	9
Installation Considerations	9
Typical Installation	10
Roof Curb and Mounting Details	11
System Assembly	12
Stack Installation	13
Fan Drainage Piping Detail	14
V Belt Drives	14
Radial Gap, Overlap and Wheel Alignment	15
Motor Wiring Method	17
Operation and Unit Start-Up	18
Maintenance	20
Lubrication	22
Exploded View	25
Field Coating Touch-Up Procedure	27
Troubleshooting	28
End of Life Disposal	29
Warranty	30
Our Commitment	31
Maintenance log	32

## Naming Convention

YFBCSL/R—1120 C1 T1 P6 — 160 — R180 — EX

Group: 1      2      3      4      5      6      7      8

Group	Length (Character)	Type	Description
1	4~6	Product Name	Represented by letters. Mandatory.
2	3~4	Nominal Impeller Diameter (mm)	Represented by numbers. Mandatory.
3	1~2	Impeller Reinforcement Class	Indicated as C + numerical code. Refer to Appendix A – Reinforcement Class Table. Required.
4	1~2	Temperature Class (°C)	T0: -40°C ≤ T0 ≤ 80°C T1: 80°C < T1 ≤ 250°C T2: 250°C < T2 ≤ 450°C  When item ④ is T0, it is omitted by default.
5	1~2	Drive Type	Indicated by letters: D – Direct drive (motor direct-coupled) P – Coupling drive  6 – Motor pole number  Belt drive is omitted
6	1~4	Motor Power kW	Numeric value, up to 4 digits with decimal allowed; dual-speed motors are separated by “/”. Mandatory.
7	1~4	Rotation Direction	Indicated by letters: R – Right-hand rotation L – Left-hand rotation  180 – Scroll rotation angle (180°)
8	1~2	Application Code	Two-letter code representing application category; selected based on structural variations. Mandatory.

**Application code :**

**GT/ General Type**

**SR/Smoke Remove Duty**

**EX/ Explosion-proof**

**FJ/ Fume Jet**

## General Safety Information

Installation of this equipment shall be performed by qualified personnel only. Personnel must read and understand these instructions and be familiar with general safety practices before proceeding.

Improper installation, operation, or maintenance may result in electric shock, serious injury, death, or damage to equipment. Contact with moving parts presents additional hazards. Additional design and installation considerations may be required for applications subject to high winds, seismic conditions, or other site-specific factors. When in doubt, consult a licensed professional engineer prior to installation or operation.

1. Comply with all applicable local, state, and national codes.  
Failure to comply with applicable codes and standards may result in personal injury, property damage, or legal liability. Verify that the fan propeller rotates freely and does not contact any stationary components.
2. Ensure the motor is properly and securely grounded in accordance with applicable codes.
3. Do not operate the fan above the maximum cataloged RPM. Use of Variable Frequency Drives (VFDs) may affect motor load. If fan speed is adjusted, verify that motor current does not exceed the nameplate rating.
4. Prevent power cables from kinking or contacting oil, grease, hot surfaces, or chemicals. Replace damaged cables immediately.
5. Confirm that the power supply is compatible with the equipment nameplate requirements prior to connection.

### **DANGER**

Always disconnect, lock out, and tag out all power sources before installing, servicing, or performing maintenance on the equipment. Failure to do so may result in electric shock, fire, serious injury, or death. It is the responsibility of the user to ensure that all energy sources are properly isolated in accordance with applicable lockout/tagout procedures and regulations.

### **CAUTION**

The motor surface may become hot during operation and could cause burns upon contact. Allow sufficient time for the motor to cool before performing any service or maintenance.

Use appropriate personal protective equipment as necessary to reduce the risk of injury.

### **CAUTION**

This equipment is not intended for use in explosive or hazardous atmospheres unless specifically designed and certified for such applications.

Use in such environments may result in fire, explosion, serious injury, or death. It is the responsibility of the user to verify that the equipment is properly rated and suitable for the intended application.

---

## Receiving, Unpacking, Handling and Storage

---

### Receiving

Upon receipt of the shipment, verify that all items have been received by comparing the delivery documents with the packing list. Inspect all crates and cartons for visible shipping damage prior to acceptance. Any damage or shortage must be noted on the delivery receipt and bill of lading and acknowledged by the carrier.

Failure to properly document damage at the time of delivery may limit the ability to file a claim with the carrier. If damage or shortages are identified, notify the carrier and your sales representative immediately. The manufacturer is not responsible for damage or loss occurring during transit or for damage identified after acceptance of the shipment.

---

### Unpacking

Carefully unpack the equipment and verify that all components and quantities match the packing list. Report any missing items to the appropriate representative without delay.

Due to shipping constraints, items associated with a single unit may arrive in multiple shipments. Verification should be limited to items listed on the applicable bill of lading.

---

### Handling

Handle all equipment in a manner that prevents damage to the protective coating and components. Do not lift the unit by the motor shaft, motor housing, or any accessories.

Damage to finishes or components may reduce the equipment's performance and resistance to corrosion. The user is responsible for ensuring proper handling practices are followed.

---

### Storage

If the equipment cannot be installed and placed into operation immediately, proper storage precautions must be taken to prevent damage or deterioration. The user assumes full responsibility for the condition of the equipment and accessories during storage. The manufacturer shall not be responsible for damage resulting from improper storage conditions.

These recommendations are provided as general guidelines only. Site-specific conditions may require additional measures.

For belt-driven units in storage, the fan impeller and drive assembly shall be rotated periodically to prevent belt deformation.

If the unit remains idle for an extended period (e.g., longer than six months), the belts may develop permanent deformation due to sustained tension at fixed contact points. This can result in uneven stress distribution, reduced belt life, and potential premature failure during operation. To avoid this, rotate the fan impeller by hand at regular intervals to redistribute belt tension and prevent localized deformation.

## Indoor Storage

Whenever possible, store equipment indoors in a clean, dry environment above grade, protected from moisture, dust, and temperature fluctuations. Maintain temperatures between -1°C and 43°C. Sudden temperature changes may result in condensation and moisture accumulation on metal surfaces.

All accessories must be stored in a clean, dry indoor location. Remove any accumulation of water, ice, snow, or debris prior to storage and ensure all components are dry. Allow cold equipment to reach room temperature before storage to prevent condensation.

If necessary, use temporary heating to maintain dry conditions. Covers should be loosely applied to allow for air circulation and periodic inspection.

Elevate the unit a minimum of 89 mm above the floor using wooden blocks with moisture-resistant barriers. Provide adequate spacing around equipment to allow for airflow and inspection access.

---

## Outdoor Storage

Outdoor storage should be avoided whenever possible. If required, equipment must be protected from standing water, snow accumulation, and ground moisture.

Place the unit on a level surface and elevate it on suitable supports to prevent contact with water and soil. Ensure sufficient support to prevent settling.

Position components to allow for air circulation, drainage, and inspection. Do not tightly cover equipment with plastic film or tarps, as this may trap moisture and promote condensation during temperature changes.

The user is responsible for implementing adequate protection measures based on environmental conditions.

## Inspection and Maintenance During Storage

---

While in storage, fans shall be inspected at least once per month. A record of all inspections and maintenance activities should be maintained for reference.

If moisture, dirt, or contamination is observed, the source shall be identified and corrected promptly to prevent deterioration of components.

During each inspection, manually rotate the fan wheel a minimum of ten (10) to fifteen (15) revolutions to distribute lubricant within the motor and bearings.

Inspect coated surfaces for signs of deterioration. If damage to the coating is identified, touch-up or recoating should be performed as necessary. Units with special coatings may require specific repair methods in accordance with coating manufacturer recommendations.

Machined surfaces protected with rust preventive coatings shall be inspected for signs of corrosion. If rust is detected, corrective action shall be taken immediately. Remove existing rust preventive using a suitable petroleum-based solvent and clean surfaces with lint-free cloths. Residual corrosion may be removed using fine abrasive materials, taking care not to damage machined surfaces or affect tolerances.

After cleaning, all treated surfaces shall be re-protected using an appropriate rust preventive compound (e.g., Tectyl® 506, Tectyl® 511M, WD-40®, or equivalent). Application methods shall ensure adequate coverage, including internal or hard-to-reach areas where applicable.

## Removing from Storage

When fans are removed from storage for installation at their final location, they shall be protected and maintained under conditions consistent with the storage requirements until placed into operation.

Prior to assembly and installation, inspect the fan and all associated components to verify that the equipment is in proper working condition. Any damage, misalignment, or missing components shall be corrected before proceeding.

1. Verify that all fasteners and set screws, including those on the fan, wheel, bearings, drive components, motor base, and accessories, are securely tightened.
2. Manually rotate the fan wheel to ensure it rotates freely and that no components are rubbing. Access to the wheel may be obtained through the bolted access panel located on the fan housing.
3. Verify proper wheel settings, including radial gap and alignment. Refer to the applicable section on Radial Gap, Overlap, and Wheel Alignment for detailed requirements.

## Lifting

### **IMPORTANT**

Fans should never be lifted by the stack, shaft, motor, motor cover, weather hood or accessories

Fans shall be rigged and moved using the designated lifting brackets provided, or by the skid when handling with a forklift, prior to mounting the stack to the fan. The location of lifting brackets may vary depending on model and size.

Handle the unit in a manner that prevents damage to the protective coating. Scratches or chips in the finish may reduce the unit's resistance to corrosion. Refer to the coating repair section of this manual for touch-up procedures.

- Lift the unit prior to installing the stack onto the fan body.
- Use standard lifting and rigging practices in accordance with applicable safety regulations.
- All lifting brackets provided on each component shall be used simultaneously during lifting operations.

- Maintain the unit in a level position at all times during lifting and installation.
- Refer to the applicable drawings for lifting point locations.

Improper rigging or handling may result in equipment damage, loss of load control, or serious injury. It is the responsibility of the user to ensure that all lifting equipment and procedures are properly rated and suitable for the application.

**Belt Drive - Arr. 1**

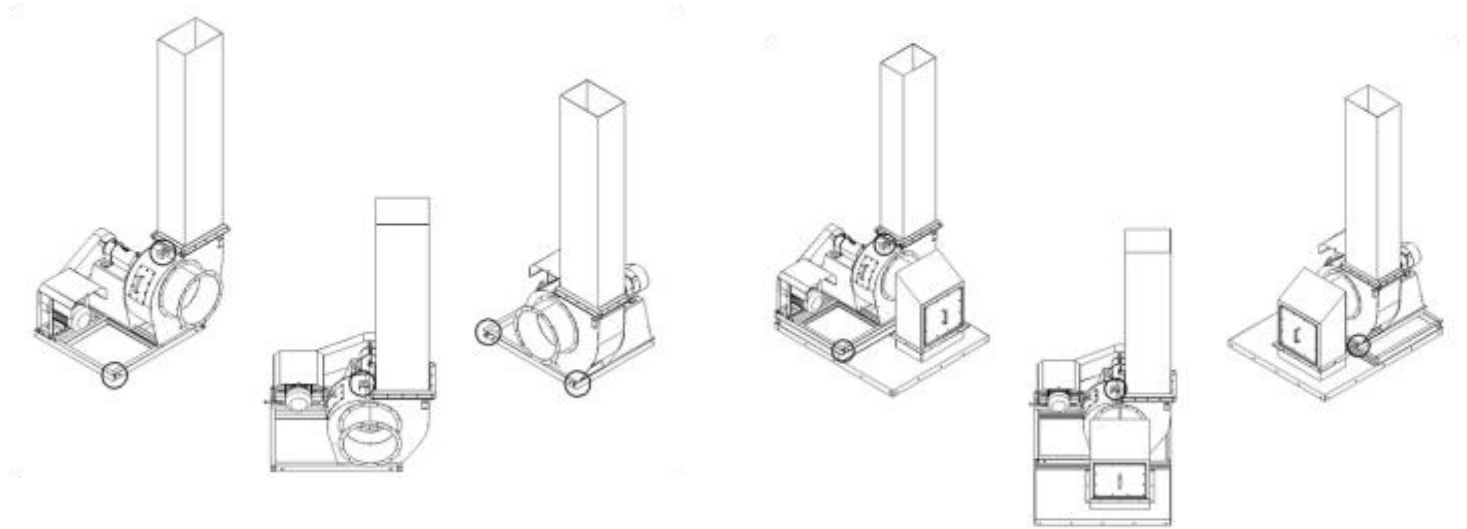

**Direct Drive - Arr. 4**

**Coupling Drive-Arr. 8**

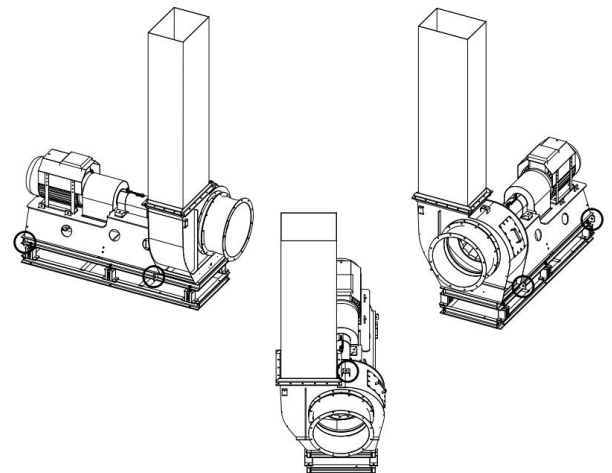
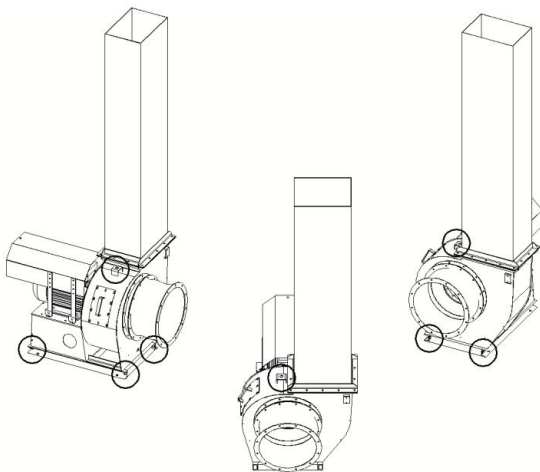

## Controlling Vibration

### Vibration Isolators (optional)

Although centrifugal fans are generally designed for smooth operation, residual vibration may be transmitted and amplified through building structures, including floors, ceilings, and connected ductwork.

To minimize vibration transmission and the resulting noise, the use of vibration isolators is recommended for floor-mounted or ceiling-suspended installations. **The fan mounting holes are Ø18 mm. Bolts used to fasten (by others) the vibration isolators to the fan shall be selected accordingly.**

Selection and application of vibration isolators shall be based on system requirements and installation conditions. Improper or inadequate vibration isolation may result in increased noise, vibration transmission, or structural impact.

### Installation Considerations

Installations with inlet or discharge configurations that deviate from the recommendations in this manual may result in reduced fan performance and increased system losses.

Restricted or unstable airflow at the fan inlet may cause pre-rotation of incoming air or uneven loading on the fan wheel, leading to reduced efficiency and increased sound levels.

Improper discharge conditions, including free discharge or turbulent flow within the ductwork, may also contribute to system effect losses.

Refer to the following diagrams for recommended installation configurations to achieve optimal performance.

It is the responsibility of the system designer and installer to evaluate airflow conditions and ensure that installation practices are appropriate for the intended application.

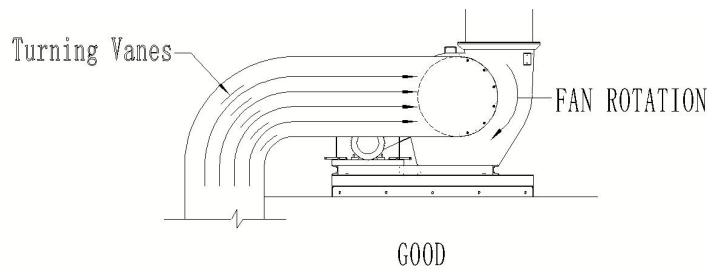
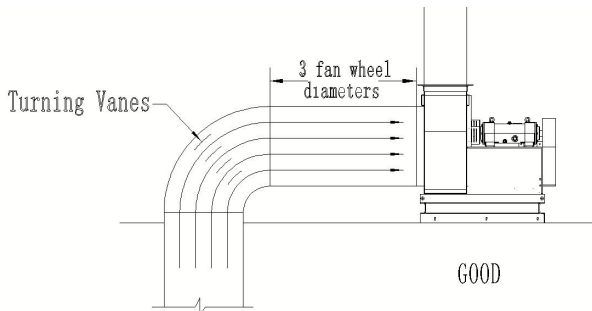
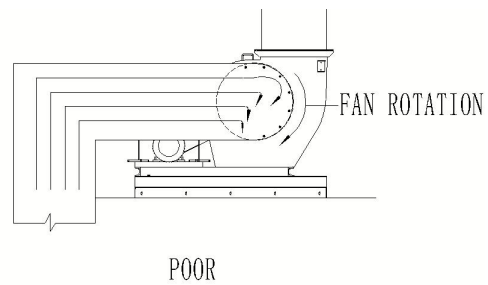
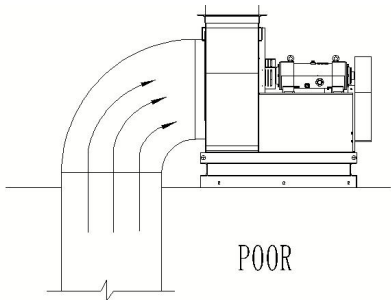

# Typical Installation

 **IMPORTANT**

### Personnel Protection and Safety Devices

When installing a fan, ensure that appropriate protective devices are provided to safeguard personnel from moving parts and other potential hazards.

### Electrical Disconnects

All fan motors shall be equipped with a disconnecting means located within sight of the equipment to allow safe isolation of electrical power. Disconnect devices shall be locked out and tagged out prior to performing any service or maintenance.

### Moving Parts

All moving components shall be equipped with suitable guards to protect personnel. Guarding requirements, including type and design, shall comply with applicable local, state, and national codes. Prior to performing any maintenance, ensure that the fan wheel is fully secured. The fan wheel may continue to rotate (“free-wheel”) even after electrical power has been disconnected. Before initial start-up or any restart, verify that all guards, including motor covers and weatherhoods, as well as all access doors, are properly installed and securely fastened.

**NOTE**

For units supplied with or operated in conjunction with a Variable Frequency Drive (VFD), refer to the VFD manufacturer’s documentation for specific installation requirements, start-up procedures, parameter settings, and troubleshooting guidelines.

VFDs provided by INFINAIR are factory programmed with basic motor parameters, incoming voltage settings, and maximum operating speed (Hz). Final configuration and verification are the responsibility of the installer based on the specific application.

All wiring and installation practices shall comply with applicable local, state, and national electrical codes. If the cable length between the VFD and the motor exceeds 30.5 m (100 ft), additional measures such as dv/dt filters or properly rated VFD cabling may be required. Determination of suitability, calculations, and proper application of these components are the responsibility of others.

Prior to installation, verify the intended airflow direction as indicated by the airflow direction label affixed to the fan. Incorrect installation may result in improper operation, reduced performance, or equipment damage.

Move the fan to the designated installation location using appropriate handling methods.



Verify that all fasteners throughout the unit are securely tightened. Secure the unit to the supporting structure using the mounting holes provided in the base angles. The unit shall be installed level; shimming may be required to achieve proper alignment.

Where noise or vibration transmission is a concern, the use of flexible duct connections and vibration isolators is recommended.

Prior to final electrical connection, verify that the motor nameplate voltage and current ratings are compatible with the available power supply. All supply wiring shall be properly protected and installed in accordance with applicable local, state, and national electrical codes.

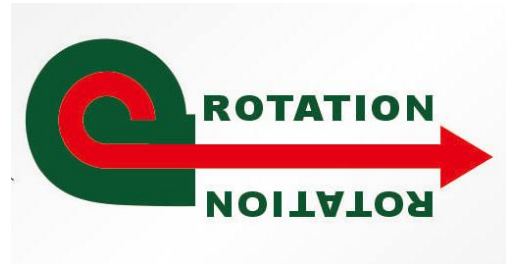

The illustration is provided for reference only. It is the responsibility of the installer to ensure that installation is performed in accordance with these instructions and applicable codes and standards.

## Roof Curb and Mounting Details(Arrangement1/4 Only)

**NOTE**

Steel, concrete or wood roof support is per structural engineer and in accordance with load requirements and applicable building codes.

The use of a roof curb is required for installations incorporating a curb cap inlet box or mega stack.

The figures illustrate common roof curbs.

The method of attachment shall be determined based on applicable local codes, roof construction design, and building materials.

Consult a qualified architect or structural engineer to determine appropriate attachment methods and ensure structural integrity.

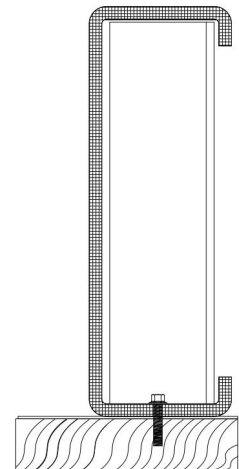
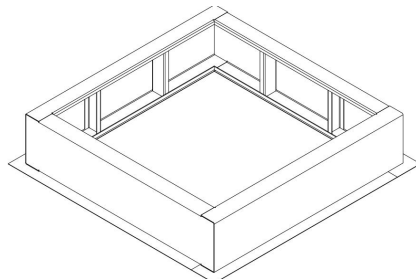

**Curb Cap with Inlet Box — Duct Connection**

Connection of the primary exhaust air duct through the curb cap and inlet box is permitted. Bottom inlet duct connections shall be provided by others.

The duct drop shall be attached to the interior panel edge of the curb cap and supported as required to maintain proper alignment and structural integrity.

All duct connections shall be sealed to prevent air leakage and water infiltration.

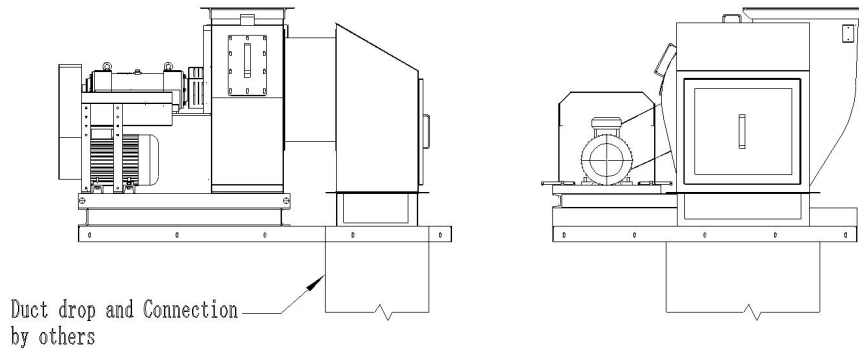

## System Assembly

### NOTE

When installing the stack and fan body, each section shall be rigged and lifted separately using the designated lifting lugs provided.



**NOTE**

When provided with isolators, manufacturer supplies information identifying isolator location and separate installation instructions.

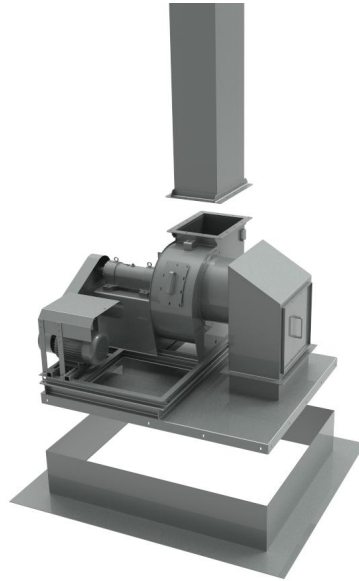

## Stack Installation

**NOTE**

Fans should never be lifted by the shaft, motor, motor cover or accessories.

### Stack Installation

1. Position the stack flange onto the fan outlet flange.
2. Align the bolt holes of the stack flange with those of the fan outlet flange, then secure them with hex head bolts, nuts, and washers of the appropriate size based on the flange hole diameter. Tighten all fasteners evenly.
3. Connect the guy-wire attachment points on the stack to ground anchors using steel wire rope to provide additional wind-load resistance and help prevent damage during hurricane or high-wind conditions.
4. Seal all field connections with an application-appropriate sealant or tape as required.



## Fan Drainage Piping Detail

Fans are provided with a drain located at the underside of the scroll housing. The drain connection is male NPT (MNPT). The drain may require connection to a suitable drainage system to ensure proper removal of water or condensate generated during operation.

- Installed piping shall be sloped downward to promote effective drainage.
- Traps shall be filled to the recommended level prior to start-up to ensure proper function.

Improper drainage installation may result in water accumulation, corrosion, or equipment damage. It is the responsibility of the installer to ensure that all drainage connections and piping are properly designed, installed, and maintained in accordance with applicable standards and site conditions.

Fan Diameter Range(mm)	Pipe Specification (female thread on both ends)	Hex Socket Plug Size(inch)
280–710	DN20mm	3/4"
800–1120	DN25mm	1"
1250–2000	DN32mm	1-1/4"

## V-Belt Drives

### V-Belt Drives Installation

1. Remove any protective coating from the fan shaft using mineral spirits or a suitable solvent. Inspect the shaft to ensure it is clean and free of nicks, burrs, or damage.
2. Install the sheaves onto the shafts. Do not force or drive sheaves into position, as this may result in bearing damage.
3. Align the fan and motor sheaves using a straightedge or equivalent method, and secure all components in place.
4. Install the belts over the sheaves. Do not pry or force the belts into position, as this may damage the belt cords and reduce service life.
5. Adjust belt tension until the belts are properly seated and moderately tensioned. Operate the unit briefly to allow the belts to seat properly.
6. With the unit shut down and all power sources disconnected, locked out, and tagged out, recheck and adjust belt tension by repositioning the motor base or pivot plate as required.

During operation, the belt drive should exhibit proper alignment, with the tight side of the belts forming a straight line between sheaves and a slight deflection on the slack side.

## Pulley and Belt Alignment

Verify that pulleys and belts are properly aligned to minimize belt wear, noise, vibration, and power loss.

The motor and driven shafts shall be parallel, and the pulleys shall be aligned in the same plane, as illustrated. Misalignment may result in premature belt failure, reduced efficiency, or damage to drive components.

Alignment shall be checked using a straightedge or other suitable method, and corrected as necessary prior to operation.

Failure to ensure proper alignment may lead to excessive wear, vibration, or equipment damage. It is the responsibility of the installer to verify and maintain proper alignment in accordance with these instructions and applicable standards.

The adjustable motor pulley is factory set to achieve the fan RPM specified for the application. Fan speed may be increased by closing the adjustable pulley or decreased by opening it.

For multi-groove variable pitch pulleys, all grooves shall be adjusted by an equal number of turns to maintain proper alignment and belt tracking.

Any increase in fan speed will result in a corresponding increase in motor load. Prior to and after any adjustment, motor current shall be measured and verified to ensure it does not exceed the motor nameplate rating.

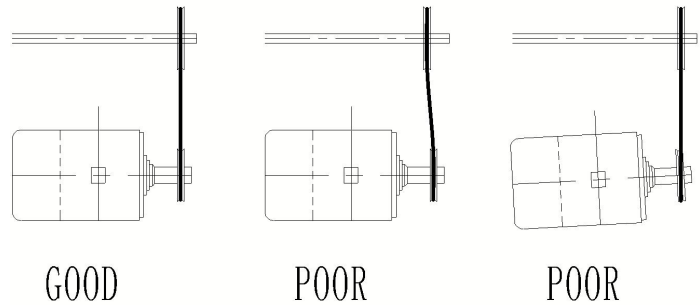

## Radial Gap, Overlap and Wheel Alignment

### Radial Gap

Adjust the inlet cone position to ensure that the radial gap between the fan wheel cone and the inlet cone is uniform around the entire circumference.

Radial gap shall be adjusted by loosening the inlet cone or inlet ring mounting bolts and repositioning the cone or ring to center it relative to the wheel. If additional adjustment is required to achieve uniform clearance, loosening the bearing mounting bolts and repositioning the shaft and wheel assembly may be used as a secondary method.

### Overlap

Overlap shall be adjusted by loosening the wheel hub from the shaft and repositioning the wheel to the required location along the shaft.

The transition between the inlet cone and the wheel shall be smooth and continuous. Improper overlap may result in reduced performance, increased turbulence, or noise.

### Wheel Centering Procedure (Belt Drive Units)

For belt-driven units, wheel centering may be achieved by one or more of the following methods:

- (a) Loosening the inlet cone mounting bolts and repositioning the inlet cone
- (b) Loosening the bearing mounting bolts and repositioning the shaft

Overlap adjustment may be performed by loosening the wheel hub set screws and moving the wheel to the desired position.

After all adjustments are completed, all fasteners and set screws shall be securely tightened. Drive pulleys shall be realigned prior to returning the unit to operation.

Failure to properly adjust radial gap, overlap, or alignment may result in reduced performance, increased vibration, or equipment damage. It is the responsibility of the installer to ensure all adjustments are performed in accordance with these instructions and applicable standards.

**Wheel Rotation**

Correct rotation of the fan wheel is critical for proper operation. Incorrect rotation may result in reduced airflow performance, increased motor loading, and potential motor failure.



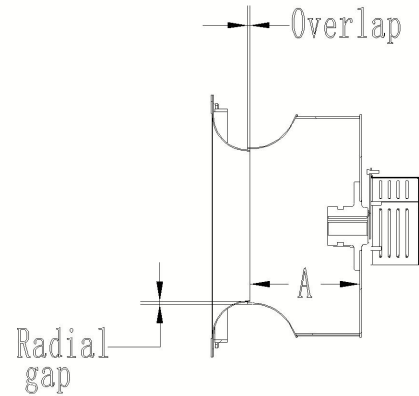

Verify wheel rotation by momentarily energizing (“jogging”) the unit and observing the direction of rotation. Rotation shall correspond to the airflow direction at the discharge and match the rotation decal affixed to the unit.



If rotation is incorrect, immediately disconnect power and correct the phase sequence before operating the unit.

Fan Diameter Range(mm)	A	Overlap	Overlap Tolerance
280–315	2.5–3 mm	10–15 mm	±3 mm
355–450	3–3.5 mm	15–20 mm	±3 mm
500–630	3.5–4 mm	20–25 mm	±3 mm
710–800	4–5 mm	25–30 mm	±3 mm
900–1000	5–6 mm	30–35 mm	±3 mm
1120–1250	0.15%~0.25% D (approx. 2–3 mm)	35–40 mm	±3 mm
1400–1600	0.15%~0.25% D (approx. 2.5–4 mm)	40–45 mm	±3 mm
1800–2000	0.15%~0.25% D (approx. 3–5 mm)	45–50 mm	±5 mm

# Motor Wiring Method

Motor Type	Motor Wiring Method	Motor Wiring Method
Single-speed three-phase motors	 <p>Y (star) connection is often used for low power motors</p>	 <p>Δ (delta) connection is often used for high power motors</p>
Two-speed three-phase motor	 <p>Low-speed Y-connection, high-speed Y-connection</p>	 <p>Low-speed Δ (or Y) connection, high-speed YY connection</p>

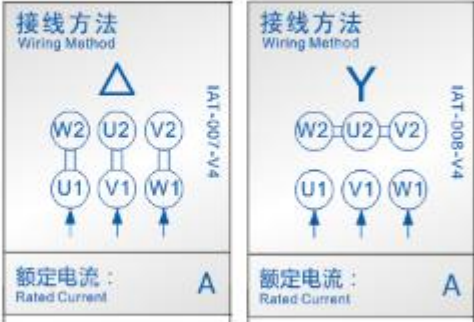
Motor Type	Variable motor wiring diagram
Three-phase variable motor	Main motor Δ-type wiring method, cooling fan Y-type wiring method
Three-phase variable motor	 <p>Main motor Δ-type wiring method, cooling fan Y-type wiring method</p>

**Motor DE/NDE Bearing and 3-Phase Winding PT100 Temperature Measurement Wiring Diagram (Option available for motor frame size 160 and above)**

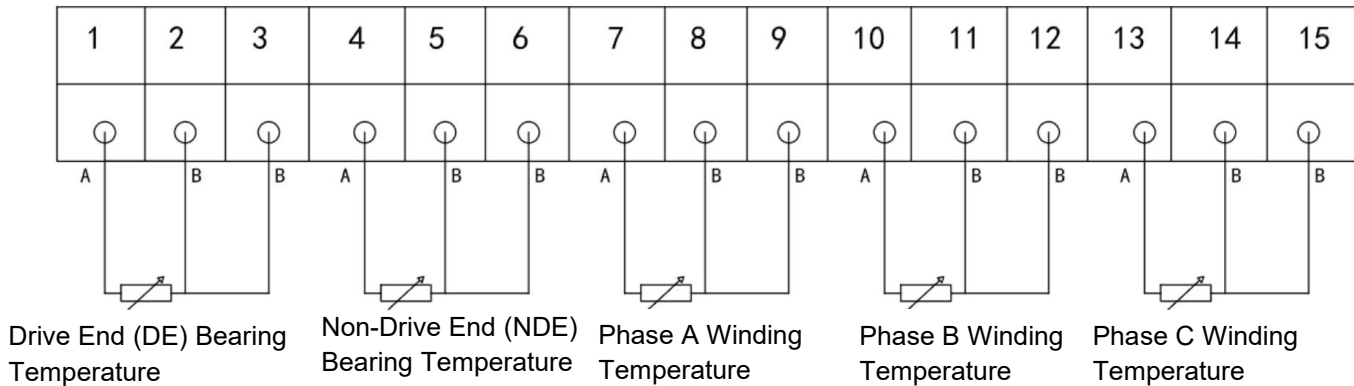

**Operation and Unit Start-Up**

**⚠ DANGER**

**This fan generates strong suction during operation. Contact with the air inlet may result in serious injury or death.**

**Keep clear of the air inlet at all times while the fan is operating. Do not place hands, tools, or any objects near the inlet. Ensure all protective guards and safety devices are properly installed and secured before operation.**

**Electrical Connections**

Prior to making any electrical connections, verify that the supply voltage, phase, and current capacity are compatible with the motor nameplate ratings.

All wiring shall be properly protected and installed in accordance with applicable local, state, and national electrical codes. Improper electrical connections may result in equipment damage, fire, or serious injury.

Power supply conductors may be connected to an optional safety disconnect switch, an optional wiring pigtail, or directly to the motor junction box, as applicable. It is the responsibility of the installer to ensure all connections are secure, properly rated, and in compliance with applicable codes and standards.

**Pre-Start-Up Checks**

Before placing the unit into operation, perform the following checks to verify proper installation and safe operating condition:

1. Verify that all fasteners are securely tightened. Fasteners may



loosen during shipment or handling. This includes motor mounting bolts, mounting hardware, and bushing bolts securing the propeller to the motor shaft.

2. Verify that the propeller rotates in the correct direction as indicated by the rotation decal on the unit.
3. Confirm that motor wiring is correct, grounding is properly established, and insulation resistance has been tested and meets applicable requirements.
4. Verify that all control components, including control panels, variable frequency drives (VFDs), and sensors, are in proper working condition and that all parameters are correctly configured.

**No-Load Trial Operation**

Perform the following procedures during initial no-load operation:

1. Momentarily energize (“jog”) the fan to verify correct rotation direction. Rotation must match the direction indicated on the fan housing. If rotation is incorrect, immediately disconnect power and correct phase sequence before proceeding.
2. Operate the fan under no-load conditions for a minimum of two (2) hours. Monitor motor bearing temperature, unit temperature, vibration levels, current, and voltage.
3. Acceptable operating limits:
  - (1) Bearing temperature  $\leq 80^{\circ}\text{C}$ ; temperature rise  $\leq 40^{\circ}\text{C}$
  - (2) Vibration velocity  $\leq 4.5\text{ mm/s}$
  - (3) Motor current shall not exceed the rated value
  - (4) Voltage fluctuation within  $\pm 5\%$  of rated voltage
4. Verify that the fan operates without abnormal noise, looseness, or air leakage, and that the control system responds properly.

**Load Commissioning and System Integration**

After successful completion of the no-load test, proceed with load operation and system integration:

1. Operate the fan under load and integrate with the ventilation control system.
2. Verify start/stop, speed control, and directional operation for single and multiple fan configurations. Operation shall be stable with appropriate system response.
3. Measure airflow, velocity, and pressure to confirm compliance with design requirements.
4. Perform fire/emergency simulation testing, including high-speed operation and smoke exhaust/reversal functions, to verify proper system response.
5. Conduct continuous load operation for a minimum of eight (8) hours. All operating parameters shall remain stable with no abnormal conditions.

Successful completion of the above procedures is required prior to final acceptance. It is the responsibility of the system integrator and commissioning personnel to ensure all tests are performed in accordance with applicable standards and project requirements.

For three-phase installations, rotation can be corrected by interchanging any two of the three power leads. For single-phase installations, follow the wiring diagram provided on the motor.

Failure to perform these checks may result in improper operation, equipment damage, or personal injury. It is the responsibility of the installer to ensure all pre-start inspections are completed prior to operation.

---

## Maintenance

---

Once the unit has been placed into operation, a routine maintenance schedule shall be established to ensure safe operation and maintain performance.

The maintenance program should include, but is not limited to, the following:

1. Lubricate the motor as required.
2. Verify that the propeller, housing, and all fasteners are securely tightened.
3. Remove any dirt or debris from the propeller and housing to prevent imbalance and potential equipment damage.
4. Inspect the fan propeller and housing for signs of fatigue, corrosion, or wear.
5. Failure to perform routine maintenance may result in reduced performance, equipment damage, or personal injury.

Before performing any service or maintenance, disconnect, lock out, and tag out all power sources and ensure the fan propeller is secured to prevent rotation.

---

## Fan Operation

Fans shall be operated at least once every thirty (30) days. At a minimum, the unit shall be momentarily energized ( “bumped” ) if full operation is not feasible.

Full operation is preferred, as it allows electrical and mechanical components to reach normal operating temperature, helps dissipate moisture and condensation, redistributes loads on bearings, and promotes proper distribution of lubricant within motor and shaft bearings.

---

## Motors

Motor maintenance is generally limited to external cleaning and lubrication. Cleaning shall be limited to exterior surfaces only. Removal of dust and grease accumulation from the motor housing is necessary to maintain proper cooling.

Do not wash down the motor or expose it to high-pressure water or steam.

Lubrication is required only for motors equipped with grease fittings. Many motors are permanently lubricated and do not require additional lubrication. For motors with grease fittings, follow the motor manufacturer's recommendations for lubrication intervals and procedures. When motor temperature does not exceed 40°C, the grease should be replaced after 2000 hours of running time.

Direct drive systems have extended grease lines to lubricate the motor without removal of any guarding.

Improper maintenance or lubrication practices, including failure to lubricate in accordance with the lubrication section, may result in motor damage or reduced service life.

---

## Fasteners and Wheel

Fan wheels generally require minimal maintenance when operating in clean air conditions. However, in applications where the air stream contains grease, dust, or other contaminants, buildup on the wheel may occur, leading to imbalance.

Accumulation of contaminants on the wheel can result in increased vibration, reduced performance, and potential equipment damage. Wheels operating in such conditions shall be inspected and cleaned at regular intervals to maintain safe and reliable operation.

All fasteners, including set screws on bearing collars, shall be inspected and verified for tightness during each maintenance interval. Loose fasteners may contribute to vibration, misalignment, or component failure.

Loose components may result in vibration, equipment damage, or personal injury.

## Removal of Dust and Dirt

Accumulation of dirt and debris may obstruct motor cooling passages, contaminate bearing lubrication, and cause imbalance of the propeller.

The exterior surfaces of the motor and propeller shall be cleaned periodically to maintain proper operation. Use caution to prevent water or cleaning agents from entering the motor.

Under no circumstances should the motor be exposed to steam or direct water spray.

The user is responsible for ensuring that appropriate cleaning methods are used and that maintenance is performed in accordance with these instructions and applicable safety practices.

## V-Belt Drive Inspection and Maintenance

V-belt drives shall be inspected on a regular basis for wear, proper tension, alignment, and accumulation of dirt or debris.

Premature or frequent belt failures may result from improper belt tension (either too loose or too tight) or misaligned sheaves. Excessive belt tension or misalignment can impose additional loads on bearings and may lead to premature failure of fan and/or motor bearings. Conversely, insufficient belt tension may result in slippage, start-up noise, belt flutter, and overheating of sheaves. Improper tension, whether excessive or insufficient, may also contribute to vibration.

When replacing belts on multi-groove drives, all belts shall be replaced as a matched set to ensure uniform load distribution. Belts shall not be pried on or off the sheaves. Loosen belt tension sufficiently to allow removal by hand. After installation, ensure that belt slack is uniformly distributed on the same side of the drive. The use of belt dressing is not recommended.

Do not install new belts on worn sheaves. If grooves are worn, the sheaves shall be replaced prior to installing new belts.

Proper belt tension is defined as the minimum tension at which belts do not slip under peak load conditions. Belt tension shall be adjusted by repositioning the motor base or pivot plate. For initial tensioning, belt deflection at the midpoint between sheaves should be approximately 1/64 inch per inch of belt span.

Belt tension shall be checked at least twice during the first 24 hours of operation and periodically thereafter.

Failure to properly inspect, install, and maintain the belt drive may

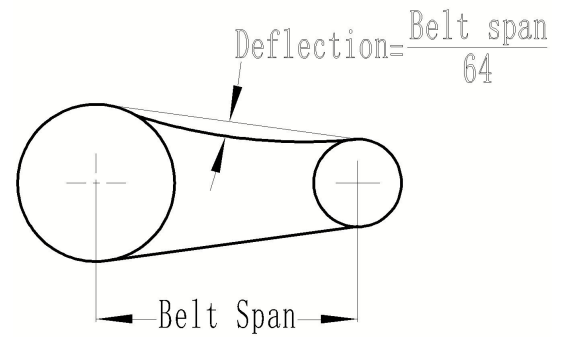

result in reduced performance, increased wear, equipment damage, or personal injury. It is the responsibility of the user to ensure that all maintenance practices are performed in accordance with these instructions and applicable standards.

## Lubrication

### Fan Bearings

Shaft bearings are critical components of the fan and require regular inspection and proper lubrication to ensure reliable operation. Bearings shall be kept clean and adequately lubricated to minimize friction and wear, facilitate heat dissipation, extend service life, and prevent corrosion.

Proper lubrication requires the use of the correct grease type applied at appropriate intervals. Refer to the recommended bearing lubrication schedule for specific requirements.

Under abnormal or severe operating conditions, including temperatures below 0°C or above 93°C, or in the presence of moisture or contaminants, more frequent lubrication may be required.

#### Lubrication Conditions Chart

<b>Bore Dia(mm)</b> <b>Fan</b> <b>Speed(RPM)</b>	<b>12~26</b>	<b>27~38</b>	<b>41~49</b>	<b>50~63</b>	<b>68~81</b>	<b>87~100</b>	
<500	6	6	6	6	5	4	Month
500~750	6	6	6	5	4	3	Month
750~1000	6	6	6	5	4	3	Month
1000~1250	5	5	5	4	3	2	Month
1250~1500	5	5	5	4	3	2	Month
1500~1750	5	4	4	3	2	1	Month
1750~2000	5	4	4	3	2	1	Month
2000~2250	4	4	3	2	1	/	Month
2250~2500	4	4	3	2	1	/	Month
2500~3000	4	3	2	1	2	/	Month

\*Exceptions to the greasing interval chart:

- Periodic Applications (any break of one week or more): it is recommended that full lubrication be performed prior to each break in operation.
- Higher Temperature: it is recommended to halve the intervals for every 17°C increase in operating temperature above 50°C not to exceed 110°C for standard bearings; high temperature bearings (optional) can operate up to 200°C.
- Vertical Shaft: it is recommended that the intervals should be halved.

INFINAIR Corporation uses petroleum lubricant in a lithium base. Other types of grease should not be used unless the bearings and lines have been flushed clean. If another type of grease is used, it should be a lithium-based grease conforming to NLGI grade 2 consistency.

A NLGI grade 2 grease is a light viscosity, low-torque, rust-inhibiting lubricant that is water resistant. Its temperature range is from -35°C to +90°C and capable of intermittent highs of +120°C. For temperatures above 120°C, Mobiltemp SHC 32 is recommended.

**Motor Bearings**

Motors are provided with pre-lubricated bearings. Any lubrication instructions shown on the motor nameplate supersede instructions below.

Motor bearings without provisions for re lubrication will operate up to 10 years under normal conditions with no maintenance. In severe applications, high temperatures or excessive contaminants, it is advisable to have the maintenance department disassemble and lubricate the bearings after 3 years of operation to prevent interruption of service.

For motors with provisions for re-lubrication, follow intervals of the table below.

**Relubrication Intervals**

Service Conditions	IEC Frame Size					
	Up to and Including 112		132-225		250 and Larger	
	1800 RPM and Less	Over 1800 RPM	1800 RPM and Less	Over 1800 RPM	1800 RPM and Less	Over 1800 RPM
Standard	3 yrs.	6 months	2 yrs.	6 months	1 yr.	3 months
Severe	1 yr.	3 months	1 yr.	3 months	6 months	1 month

Motors are provided with a polyurea mineral oil NGLI #2 grease. All additions to the motor bearings are to be with a compatible grease such as Exxon Mobil Polyrex EM and Chevron SRI.

The above intervals should be reduced to half for vertical shaft installations.

**Bearing Housing — Lubrication and Maintenance(Coupling drive)**

**Lubrication Method**

The bearing housing is lubricated using an oil bath system, in which a portion of the bearing is immersed in lubricant. During operation, rotating components distribute the oil throughout the bearing assembly before returning it to the reservoir.

Oil level shall be maintained within the recommended range, typically near the centerline of the lowest rolling element. Due to agitation and temperature rise during operation, lubricant loss may occur. The oil level shall be monitored regularly using the sight glass and replenished as required.

## Lubricant Specification

Use ISO VG32 to VG46 mineral-based lubricating oil (or equivalent), unless otherwise specified.

## Bearing Cooling

For operating temperatures up to 250°C, heat dissipation is achieved through the lubricating oil.

For operating temperatures above 250°C, water cooling is required. Cooling water pressure shall be maintained between 0.2–0.3 MPa, with a flow rate of approximately 0.5–1.0 t/h.

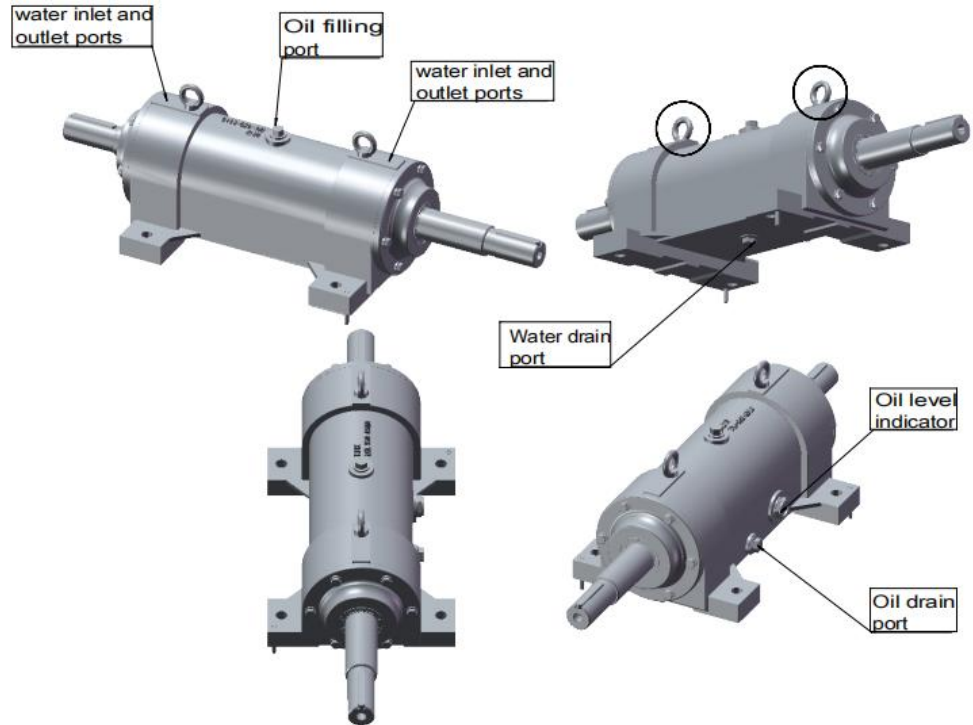

## Oil Filling Procedure

To add lubricant, remove the fill plug and use a suitable funnel to introduce oil into the housing. Fill to the level indicated on the sight glass, typically within approximately 5 mm of the centerline.

Overfilling or underfilling may result in inadequate lubrication, overheating, or equipment damage.

## Lubrication Interval and Oil Replacement

Lubrication intervals depend on operating conditions:

If the lubrication interval is less than six (6) months, periodic replenishment is recommended.

If the interval exceeds six (6) months, complete oil replacement is recommended.

Oil change frequency shall be determined based on operating conditions:

For operating temperatures  $\leq 50^\circ\text{C}$  with minimal contamination, replace oil at least once per year.

For temperatures  $> 50^\circ\text{C}$ , oil shall be replaced more frequently, typically every three (3) months.

Under severe conditions (e.g., moisture ingress or contamination), oil shall be replaced immediately.

Oil replenishment and replacement intervals are condition-based and shall be adjusted according to actual inspection results. If any abnormal oil condition is observed, the lubricant shall be replaced without delay.

## Lubrication Safety

Lubrication shall be performed only when the unit is in a safe condition. Disconnect, lock out, and tag out all power sources prior to servicing. If rotation is required for lubrication, ensure that proper safety precautions are in place and manually rotate the fan where possible.

## Lubricant Change Procedure

When changing lubricant type or grade, completely drain the existing oil and thoroughly clean the bearing housing and reservoir before refilling. Failure to do so may result in premature bearing failure.

## Water-Cooled Bearing Housing (Special Considerations)

Water-cooled bearing housings are equipped with a drain port at the bottom. After pressure testing, all cooling water shall be drained completely.

In ambient temperatures below 0°C, cooling water must be drained after shutdown to prevent freezing and potential damage to the housing. Where applicable, antifreeze solutions or circulation systems may be used to prevent freezing.

Failure to properly manage cooling water may result in equipment damage or loss of functionality.

## Exploded View

Each fan is provided with a manufacturer's nameplate that includes the model number and serial number. This information, along with the applicable parts diagram, is required when requesting service, technical support, or replacement parts.

Nameplates are typically located in a visible area on the unit, commonly near the fan outlet. The exact location may vary depending on the fan model and size.

It is the responsibility of the user to ensure that the nameplate remains legible and accessible. Failure to provide accurate identification information may delay service, support, or parts replacement.

### Direct Drive-Shown with optional accessories, spring isolators

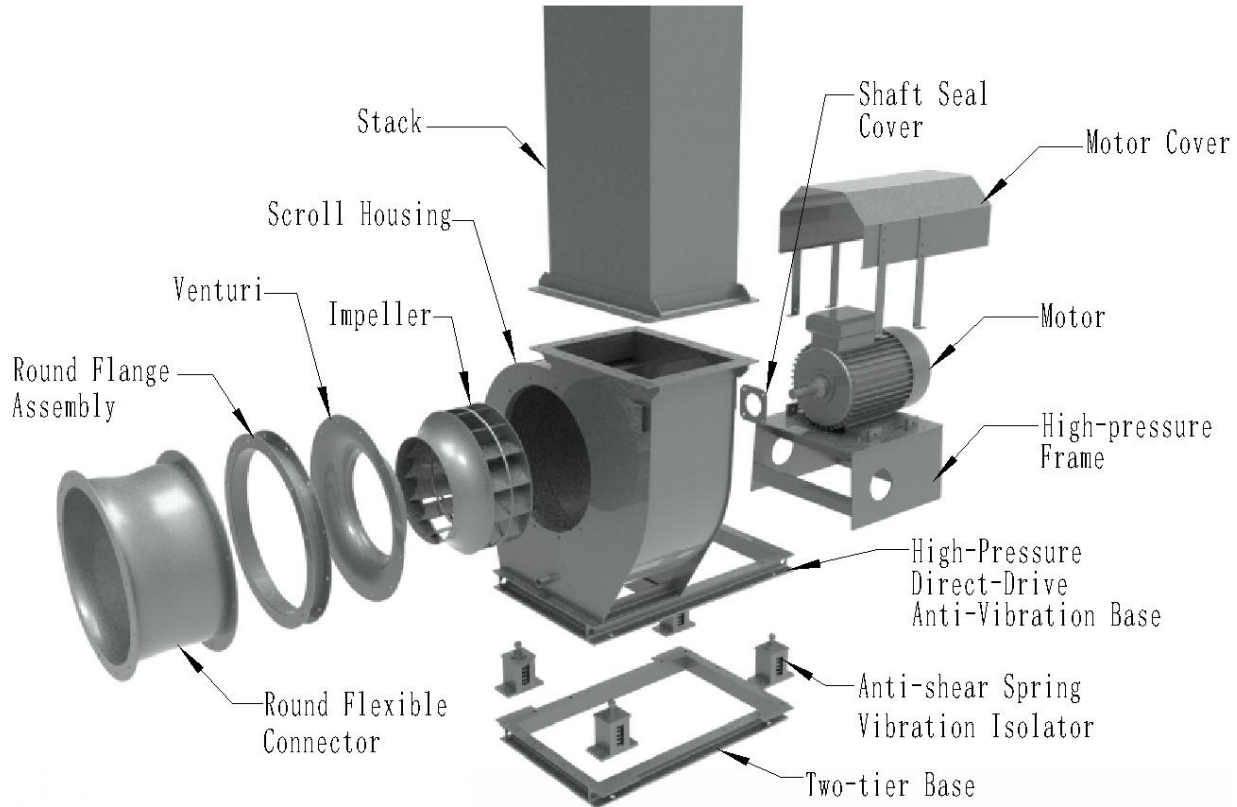

**Coupling Drive-Shown with optional accessories, spring isolators**

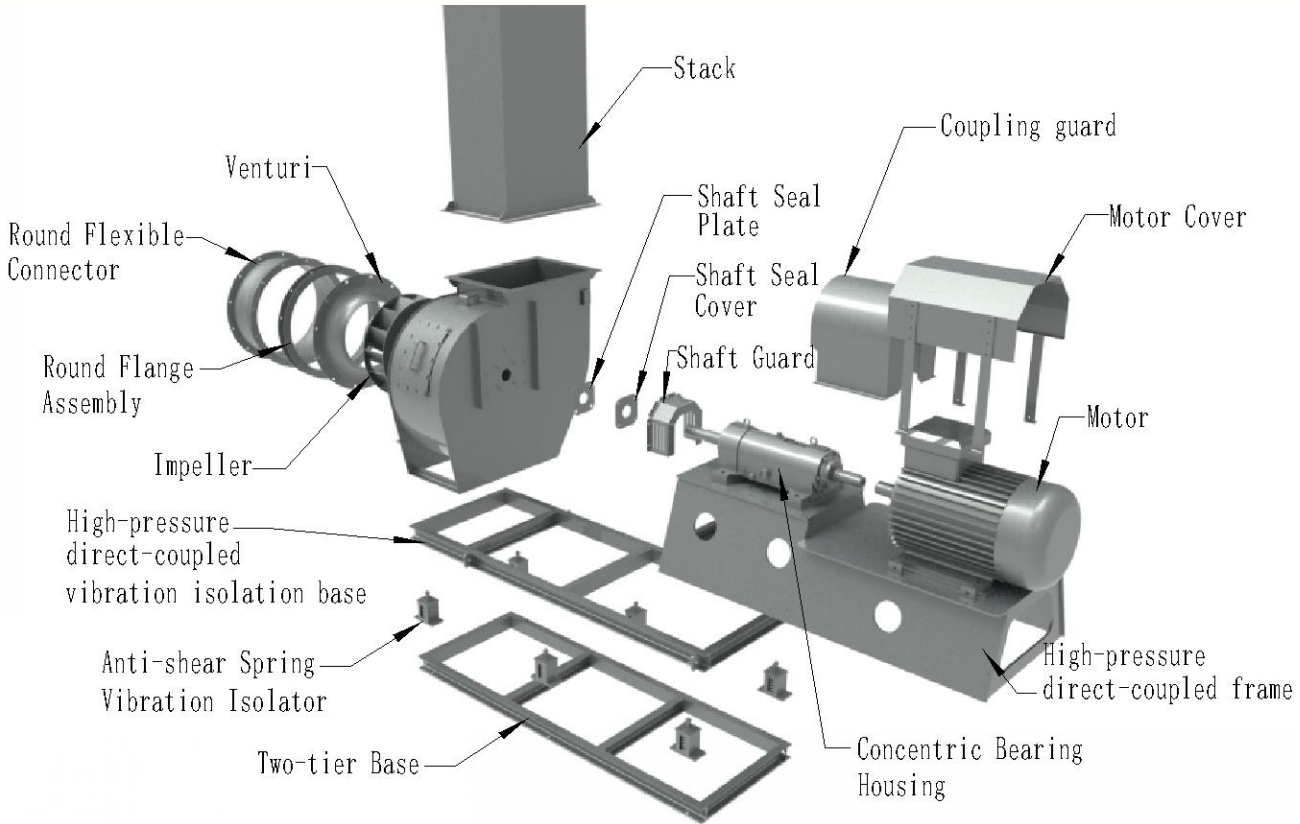

**Belt Drive-Shown with optional accessories, curb cap inlet box and inlet flanges**

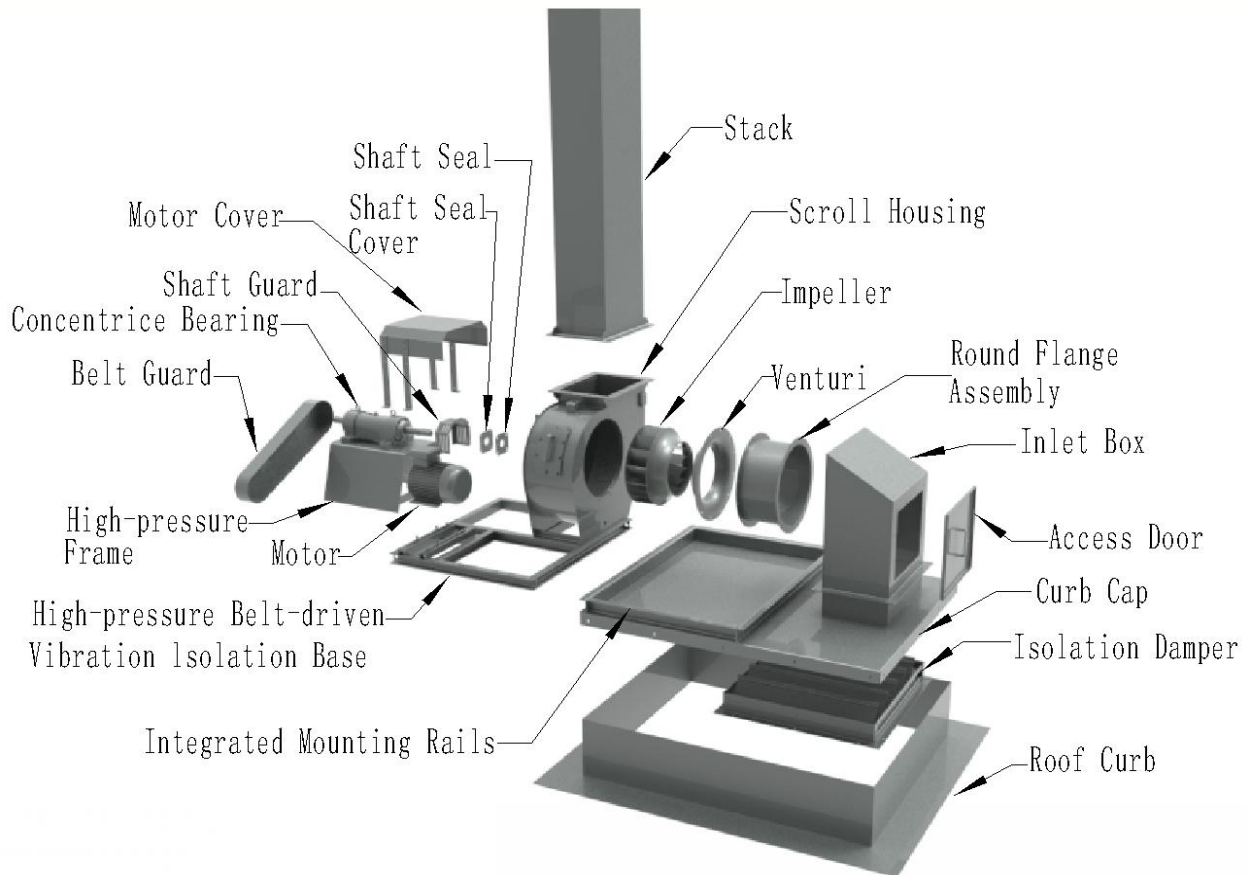

## Field Coating Touch-Up Procedure

Standard coating/color: RAL9006, or the other color card specified in the order. The procedure outlines the correct method for repairing minor scratches in the coating.

### TOUCH-UP PAINT REPAIR KIT CONTENTS

- One pint of primer including a technical data sheet
- One pint of industrial enamel including a technical data sheet
- Four disposable foam brushes
- One sheet sand paper
- Repair procedure details

1. Prepare the affected area by lightly abrading the surface using medium-grit sandpaper or a medium Scotch-Brite™ pad. Feather the edges to ensure a smooth transition.
2. Clean the prepared area using an alkaline-based cleaner, then rinse thoroughly and allow the surface to dry.
3. Apply primer using a suitable applicator. Follow the primer manufacturer's technical data sheet for application instructions.
4. Allow the primer to dry for a minimum of 2.5 hours, or as specified by the product technical data sheet, prior to applying the topcoat.
5. Apply the topcoat using an industrial enamel coating in accordance with the manufacturer's technical data sheet. Allow sufficient time for air drying and curing before placing the unit into service. Refer to the technical data sheets for detailed curing schedules based on ambient conditions.

### NOTE

While the equipment is manufactured with durable coatings suitable for demanding environments, periodic inspection and touch-up may be required, particularly in coastal or marine environments where exposure to salt air can accelerate coating degradation.

Damage such as scratches, chips, or abrasions may compromise the protective coating and should be repaired promptly to prevent corrosion. Environmental conditions may significantly affect coating life, and additional maintenance may be required based on site-specific exposure.

Please contact factory with your fan's serial number for colors other than our standard.

### Tips to Prolong Coatings Integrity

- Remove debris, metal shavings, or installation residue from surfaces that may promote coating damage.
- Inspect the unit at least annually for signs of corrosion or coating damage, and perform touch-up as required.
- Clean exterior surfaces periodically using a mild detergent and rinse thoroughly.

The user is responsible for establishing an appropriate inspection and maintenance schedule based on operating conditions and environmental exposure.

## Troubleshooting

Problem	Cause	Solution
Excessive Noise or Vibration	Friction between Impeller and casing	Adjust clearance between impeller and casing
	Damaged motor bearings	Replace bearing
	Loose fasteners	Inspect and tighten all fasteners
	Contaminated impeller or incorrect rotation direction	Clean impeller and verify correct rotation direction
Increased Pressure with Reduced Airflow	Abnormal air density due to impurities or temperature variation	Check air conditions and correct as required
	Damaged outlet duct or leaking flange	Repair duct work or replace flange gasket
	Fluctuation of rotate speed	Stabilize fan speed
	Blocked inlet or outlet	Inspect and clean ducts and valves
Fan and Motor vibration	Severe impeller corrosion or excessive buildup	Clean impeller or replace if necessary
	Motor	Check motor condition and ensure overload protection is properly set
Excessive motor current and overheating	Start before wind damper are closed	Open the valve when starting fan
	Fan system fault	Check fan system duct net, Adjust system working condition.
	Motor fault	Examine and repair motor
	Power supply issue	Verify power supply and electrical connections

---

## End of Life Disposal

---

At the end of the product service life, this equipment must be disconnected from all power sources before removal or dismantling. Disassembly and removal shall be performed by qualified personnel in accordance with applicable local, state, and federal regulations.

This product and its components shall not be disposed of as unsorted municipal waste. Metal components should be separated and recycled where appropriate facilities exist. Motors, wiring, switches, and any other electrical or electronic components shall be handled through authorized recycling or disposal channels in accordance with applicable regulations.

Any lubricants, grease, oil-contaminated materials, coatings, or other potentially regulated substances shall be collected and disposed of in accordance with applicable environmental and waste handling requirements. Do not discharge oils, grease, or other residues into drains, soil, or waterways.

Packaging materials, including wood, cardboard, plastic film, and foam, should be sorted and recycled or disposed of in accordance with local waste management regulations.

The owner/operator is responsible for proper end-of-life handling, recycling, and disposal of the equipment and its components. Improper disposal may result in environmental harm and may violate applicable regulations.

### CERTIFICATIONS AND STANDARDS

#### REGULATORY COMPLIANCE & CERTIFICATIONS

This equipment is designed and manufactured in accordance with recognized industry standards, including but not limited to OSHA, NFPA, NEC, AMCA, and ASHRAE, where applicable. This equipment may be provided with certifications or listings such as AMCA Certified Ratings and UL/ETL Listing depending on model and configuration. Certification status varies by model and configuration. Refer to the equipment nameplate, product labeling, or project submittals for specific certification details.

**All installations shall comply with applicable local, state, and national codes and the requirements of the Authority Having Jurisdiction (AHJ).**

**Certifications apply only to specific models and configurations and are subject to project requirements.**

---

## Warranty

---

INFINAIR warrants that products manufactured under the “INFINAIR™” brand shall be free from defects in material and workmanship for a period of eighteen (18) months from the date of shipment.

During the warranty period, INFINAIR will, at its option, repair or replace defective components at no charge, provided the product has been installed, operated, and maintained in accordance with this manual. This warranty does not cover consumable or wear items, including but not limited to belts, filters, or similar components.

Except as expressly stated herein, INFINAIR shall not be responsible for any additional costs, losses, or damages, including but not limited to labor, downtime, or consequential damages.

---

## Limitations and Exclusions

This warranty does not apply to damage or failure resulting from, but not limited to, the following conditions:

- Operation of the product outside of specified design or contractual conditions, including but not limited to temperature, corrosive environment, gas composition, power supply, or system resistance.
  - Improper handling, transportation, storage, or site conditions leading to equipment damage.
  - Improper maintenance, site incidents, lack of required protection (such as overheat protection), prolonged reverse operation, or any use not in accordance with this Installation, Operation, and Maintenance manual.
  - Unauthorized disassembly, modification, or reassembly of the product.
  - Alteration, removal, or misuse of the product serial number.
- 

## Product Identification

Each fan is equipped with a nameplate bearing a unique serial number. This information is required for service support and replacement parts.

It is the responsibility of the user to record and retain this information. Failure to provide accurate identification may delay service or parts replacement.

## Our Commitment

---

As part of its ongoing product development and improvement efforts, INFINAIR reserves the right to revise product specifications and design features without prior notice. It is the responsibility of the user to verify that the information provided is current and applicable to the specific equipment in use.

Warranty terms, conditions, and limitations are available on the INFINAIR website, either on the applicable product page or within the literature section. Users are responsible for reviewing all warranty information prior to installation, operation, or maintenance.

Additional details regarding equipment characteristics, performance data, available accessories, and application considerations can be found in the High Performance Fans catalog. It is the responsibility of the user to ensure proper selection, installation, and operation in accordance with all applicable guidelines and requirements.



**Reliable · Responsive · Rewarding**

**INFINAIR™**

Phone: +86 21-3918 5688 | Fax: 021-3918 5688 | E-mail: [intservice@infinair.com](mailto:intservice@infinair.com) | Website: [www.infinair.com](http://www.infinair.com)

Address: No.55, Qingneng Road, Waigang Town, Jiading District, Shanghai, P.R. China

